

150 • 250 • 160 • 260 • 170 • 270 Series  
**Regenerative  
Turbine Pumps**



- Capacities to 150 GPM
- Heads to 1150 Feet



**MTH PUMPS**

# 150 • 250 • 160 • 260 • 170 • 270 Series Regenerative Turbine Pumps

**MTH 150 • 250 • 160 • 260 • 170 • 270 Series** regenerative turbine pumps represent the most economical, high performance alternative for low flow (to 150 GPM) applications involving moderate to high pressures (heads to 1150 feet). By combining years of regenerative turbine pump designs with precision computer controlled manufacturing, the 150 • 250 • 160 • 260 • 170 • 270 Series delivers high efficiency pumping operation, even at low NPSH. High quality parts and an easily serviceable design provide low maintenance and long life.

## WATER PASSAGE DESIGN

MTH has combined sixty years of water passage design with a multistage mechanical concept to achieve maximum capacity and pressure while minimizing horsepower requirements. By optimizing the number of pumping stages with each water passageway, MTH improves both efficiency and pressure in the 150 • 250 • 160 • 260 • 170 • 270 Series, exceeding the standards realized by previous techniques.

## IMPELLER PROFILE

One of the most notable improvements in regenerative turbine pump technology

incorporated in 150 • 250 • 160 • 260 • 170 • 270 Series pumps involves the ability to determine the optimum impeller width and blade length. These factors have a significant effect on the required horsepower versus pressure curve for regenerative turbine pumps. By optimizing these for each 150 • 250 • 160 • 260 • 170 • 270 Series pump, peak efficiency is improved and “off peak” horsepower requirements are reduced as well.

## IMPELLER BLADES

After the most favorable impeller profile has been determined for a particular water passageway cross-section, MTH calculates the number of blades needed to maximize the performance of that pump. Current blade design in 150 • 250 • 160 • 260 • 170 • 270 Series pumps increases both efficiency and design pressure without the manufacturing difficulties associated with producing contoured blade impellers. State-of-the-art computer controlled machines simplify manufacturing of the various MTH impellers utilized in the 150 • 250 • 160 • 260 • 170 • 270 Series. The result is a high performance pump providing efficiency characteristics exceeding those of more expensive units.

## NPSH REQUIREMENTS

150 • 250 • 160 • 260 • 170 • 270 Series regenerative turbine pumps meet low net positive suction head (NPSH) requirements without efficiency loss. This is achieved by keeping the inlet fluid velocity low and then gently accelerating to passageway velocities.

## LOW NPSH REQUIREMENTS

250 • 260 • 270 Series regenerative turbine pumps provide exceptionally low NPSH requirements to suit boiler feed water deaerator applications. This reduced NPSH is obtained by using a first stage centrifugal Francis vane impeller with inlet flow paths shaped to maintain a constant fluid velocity. This reduces entry losses to the impeller as well as maintaining pump efficiency. A multi-vane diffuser is used in conjunction with the centrifugal impeller for balancing radial loads and extracting the maximum pressure from the flow produced by the first stage impeller. Pressure and flow produced by the low NPSH inducer assures that the succeeding stages are adequately fed.

## STANDARD MATERIALS

PART	BRONZE FITTED	ALL IRON	BRONZE RING	ALL BRONZE	STAINLESS STEEL
Cover	Cast Iron ASTM A48	Cast Iron ASTM A48	Cast Iron ASTM A48	Bronze ASTM B62	Stainless Steel AISI 316
Seal Cup	Cast Iron ASTM A48	Cast Iron ASTM A48	Cast Iron ASTM A48	Bronze ASTM B62	Stainless Steel AISI 316
Bearing Arm	Cast Iron ASTM A48	Cast Iron ASTM A48	Cast Iron ASTM A48	Bronze ASTM B62	Stainless Steel
Channel Ring	Cast Iron ASTM A48	Cast Iron ASTM A48	Bronze ASTM B62	Bronze ASTM B62	Stainless Steel AISI 316
Impeller	Bronze ASTM B62	Carbon Steel	Bronze ASTM B62	Bronze ASTM B62	W88 ASTM A494
Shaft	Stainless Steel AISI 416	Stainless Steel AISI 416	Stainless Steel AISI 416	Stainless Steel AISI 316	Stainless Steel AISI 316
“O”Rings	Buna N	Buna N	Buna N	Buna N	Viton A
Seals	EPR/Carbon	EPR/Carbon	EPR/Carbon	Buna/Carbon	Viton/Carbon
Seats	EPR/Ceramic	EPR/Ni-Resist	EPR/Ni-Resist	Buna/Ceramic	Viton/Ceramic
Ball bearing	#206	#206	#206	#206	#206

## LIMITATIONS

Discharge Pressure	500 PSI
Seal Pressure*	200 PSI
Suction Pressure (Min.)	26” Hg Vac.
Speed	1750 RPM
Horsepower	60 HP
<b>Temperature</b>	
Standard Construction	-20°F
Ceramic Seal Seat - Water	230°F
Silicon Carbide Seal Seat & External Seal Flush	250°F

\*Suction Pressure Plus a Percentage of Differential Pressure



**WARNING:**  
CANCER AND REPRODUCTIVE HARM  
WWW.P65WARNINGS.CA.GOV

## Design Features

**MTH 150 • 250 • 160 • 260 • 170 • 270 Series** regenerative turbine pumps are engineered to provide long life, low-maintenance service for low-flow applications involving moderate to high pressures -- such as boiler feed and similar uses. Available in single, two, three, or four stage models, MTH pumps offer these proven design features...

### Steep Operating Characteristics.

Near-constant capacity is maintained over wide variations in pressure. High shut-off pressure overcomes temporary line resistance.

**No Vapor Binding.** MTH impellers are designed to handle up to 20% vapor in the liquid being pumped.

**No Metal to Metal Contact.** MTH clearances enable handling of non-lubricating fluids while maintaining adequate heads.

**Low Head Requirements.** MTH pumps have excellent NPSH characteristics, which makes them ideally suited for difficult applications.

**Minimum Shaft Deflection** provided by heavy-duty outboard bearing supports on both sides of the impeller.

**Balanced Radial Loads.** On multi-stage MTH pumps, radial load equalization is designed into the pump.

**Standard Pumps Are Bronze Fitted** and have hydraulically balanced impellers, one-inch stainless steel shafts, and corrosion-resistant seals throughout.

**Mechanical Seals** incorporate EPR seals, ceramic or Ni-resist faces, and stainless steel components. These advanced seals permit elevated-temperature operation even with aggressive fluids.

**Lip-Sealed #204 Ball Bearings** on both inboard and outboard

ends, operate within rugged cast-iron bearing supports and are permanently lubricated for maintenance-free long life.

**Replaceable Channel Rings** of 30,000 PSI cast iron, and Buna "O" rings at all sealing points, contribute to trouble-free operation

## Optional Features

**Construction Materials.** Bronze fitted, all iron, all bronze and 316 stainless steel are available as stock materials.

**Mechanical Seals.** Buna, EPR, viton, Neoprene or teflon elastomers, tungsten or silicone carbide seats and balanced or double seal arrangements are all available.

**"O" Ring Gaskets.** Buna, EPR, viton, neoprene or teflon are all available.

**External Water Seal Connection.** Tapped openings can be provided for seal flushing from an external source.

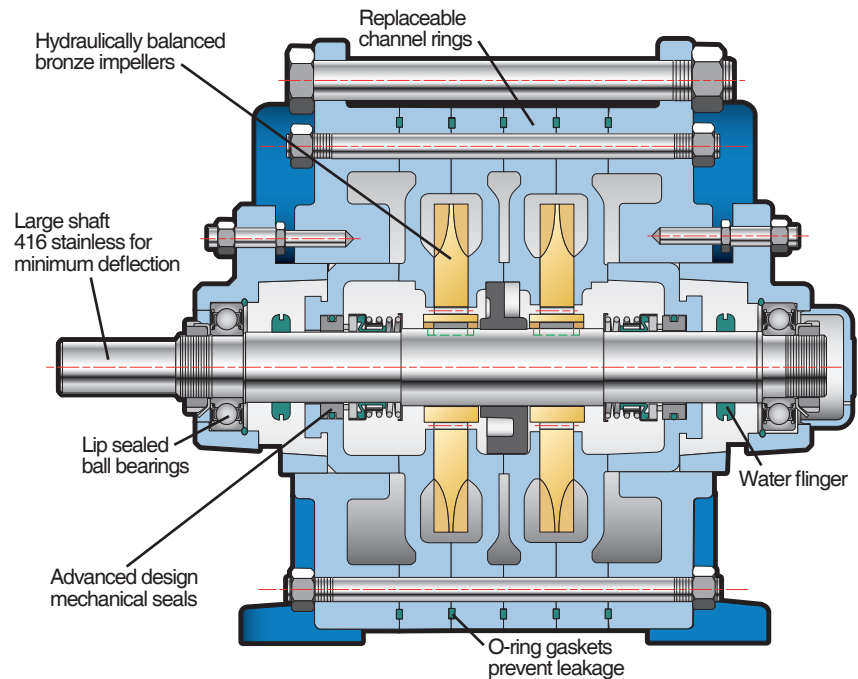

## 200 Series Inducer for Low NPSH



*The 200 Series inducer style pumps are ideally suited to applications where available NPSH at the pump inlet is limited, such as boiler feed water deaerator service.*

*A centrifugal Francis vane impeller with low NPSH characteristics is utilized as the pump's first stage impeller, accounting for the lower inlet head requirement.*

*This first stage impeller is used in conjunction with a multi-vane diffuser to provide the NPSH required by the second stage regenerative turbine.*

*Available NPSH as low as two feet can be effectively handled with 250 • 260 • 270 Series pumps, depending on the pump model and capacity.*

## Regenerative Turbine Principles

The primary difference between a centrifugal and a regenerative turbine pump is that fluid only travels through a centrifugal impeller once, while in a turbine, it takes many trips through the vanes. Referring to the cross-section diagram, the impeller vanes move within the flow-through area of the water channel passageway. Once the liquid enters the pump, it is directed into the vanes which push the fluid forward and impart a centrifugal force outward to the impeller periphery. An orderly circulatory flow is therefore imposed by the impeller vane which creates fluid velocity. Fluid velocity (or kinetic energy) is then available for conversion to flow and pressure depending on the external system's flow resistance as diagrammed by a system curve.

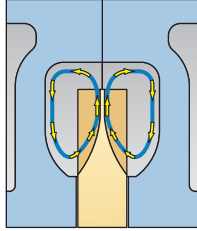

an MTH regenerative turbine, close internal clearances are required. In many cases, depending on the size of the pump, impeller to casing clearances may be as little as one-thousandth of an inch on each side. Therefore, these pumps are suitable for use only on applications with clean fluids and systems. In some cases, a suction strainer can be used successfully to protect the pump.

Next, as the circulatory flow is imposed on the fluid and it reaches the fluid channel periphery, it is then redirected by the specially shaped fluid channels, around the side of the impeller, and back into the I.D.

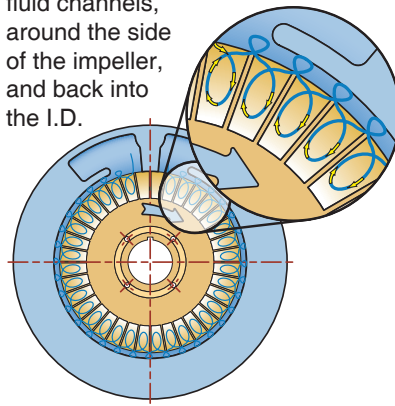

of the turbine impeller vanes, where the process begins again. This cycle occurs many times as the fluid passes through the pump. Each trip through the vanes generates more fluid velocity, which can then be converted into more pressure. The multiple cycles through the turbine vanes are called regeneration, hence the name regenerative turbine. The overall result of this process is a pump with pressure building capability ten or more times that of a centrifugal pump with the same impeller diameter and speed.

In some competitive designs, you will find that only a single-sided impeller is used. That design suffers from a thrust load in the direction of the motor that must be carried by the motor bearings. MTH turbines use a two-sided floating impeller design that builds pressure equally on both sides. This has the advantage of allowing the pump pressure to hydraulically self-center the impeller in the close clearance impeller cavity, while not burdening the motor bearings with excessive thrust loads.

It is useful to note at this point, that in order to prevent the internal loss of the pressure building capability of

150 • 250 • 160 • 260 • 170 • 270 SERIES

## Engineering Specifications

### 150 • 160 • 170 Series

The contractor shall furnish (and install as shown on the plans) an MTH Turboflex regenerative type pump model \_\_\_\_\_ size \_\_\_\_\_ of (BRONZE FITTED) (BRONZE RING) (ALL IRON) (ALL BRONZE) (316 STAINLESS STEEL) construction. Each pump shall have a capacity of \_\_\_\_\_ GPM when operating at a total head of \_\_\_\_\_ feet at the specified temperature, viscosity, specific gravity, and with \_\_\_\_\_ feet NPSHA. The maximum speed shall not exceed 1750 RPM. Pump shall be of the vertically split case design with removable bearing housings and is to be furnished with mechanical seals. The channel rings shall be replaceable external type. The suction connection shall be \_\_\_\_\_" NPT located in the top vertical position and be cast separately from the discharge. The discharge shall be \_\_\_\_\_" NPT in the top horizontal position and the pump shall be self-venting. The impeller(s) shall be located on a stainless steel shaft between sealed grease lubricated ball bearings. The impeller(s) shall be hydraulically self positioning with no external adjustment

necessary. Each pump shall be tested at the specified capacity and head prior to shipment. The pump shall be mounted on a steel baseplate, flexibly coupled with aluminum guard to a \_\_\_\_\_HP \_\_\_\_\_phase \_\_\_\_\_Hertz \_\_\_\_\_volt \_\_\_\_\_RPM horizontal (DRIP-PROOF) (TOTALY ENCLOSED) (EXPLOSION PROOF) motor. The motor is to be sized to prevent overloading at the highest head condition listed in the specification.

### 250 • 260 • 270 Series

The contractor shall furnish (and install as shown on the plans) an MTH Turboflex low NPSH inducer style regenerative type pump model \_\_\_\_\_ size \_\_\_\_\_ of (BRONZE FITTED) (BRONZE RING) (ALL IRON) (ALL BRONZE) (316 STAINLESS STEEL) construction. Each pump shall have a capacity of \_\_\_\_\_ GPM when operating at a total head of \_\_\_\_\_ feet at the specified temperature, viscosity, specific gravity, and with \_\_\_\_\_ feet NPSHA. The maximum speed shall not exceed 1750 RPM. Pump shall be low NPSHR inducer style design with a centrifugal Francis vane design impeller

and a multi-vane diffuser for balancing radial loads. Pump shall be of the vertically split case design with removable bearing housings and is to be furnished with mechanical seals. The channel rings shall be replaceable external type. The suction connection shall be \_\_\_\_\_" NPT located in the top vertical position and be cast separately from the discharge. The discharge shall be \_\_\_\_\_" NPT in the top horizontal position and the pump shall be self-venting. The impeller(s) shall be located on a stainless steel shaft between sealed grease lubricated ball bearings. The impeller(s) shall be hydraulically self positioning with no external adjustment necessary. Each pump shall be tested at the specified capacity and head prior to shipment. The pump shall be mounted on a steel baseplate, flexibly coupled with aluminum guard to a \_\_\_\_\_HP \_\_\_\_\_phase \_\_\_\_\_Hertz \_\_\_\_\_volt \_\_\_\_\_RPM horizontal (DRIP-PROOF) (TOTALY ENCLOSED) (EXPLOSION PROOF) motor. The motor is to be sized to prevent overloading at the highest head condition listed in the specification.

## Cold Water Selection Guide

HEAD IN FEET	U.S. GALLONS PER MINUTE													
	10	20	30	40	50	60	70	80	90	100	110	120	130	140
	Model	Model	Model	Model	Model	Model	Model	Model	Model	Model	Model	Model	Model	Model
50	*	*	151I 2 HP	161D 2 HP	161E 3 HP	161E 3 HP	161G 3 HP	161G 3 HP	171H 5 HP	171H 5 HP	171J 5 HP	171J 5 HP	171K 5 HP	171K 5 HP
100	*	*	151I 2 HP	151K 3 HP	161E 5 HP	161F 5 HP	161G 5 HP	171H 5 HP	171H 5 HP	171J 7.5 HP	171K 7.5 HP	171K 7.5 HP	172K 10 HP	173K 15 HP
150	*	*	161D 3 HP	161E 5 HP	161F 5 HP	161G 7.5 HP	171H 7.5 HP	171J 7.5 HP	171K 10 HP	171K 10 HP	172J 10 HP	172K 15 HP	173K 15 HP	174K 15 HP
200	*	151I 3 HP	161D 5 HP	161E 7.5 HP	161G 7.5 HP	171H 10 HP	171J 10 HP	171K 10 HP	172H 10 HP	172J 15 HP	172K 15 HP	173K 15 HP	173K 15 HP	
250	*	151I 5 HP	151K 5 HP	152K 7.5 HP	161G 10 HP	162G 10 HP	163G 15 HP	172H 15 HP	172J 15 HP	172K 15 HP	172K 15 HP	173K 20 HP	173K 20 HP	
300	*	151I 5 HP	151L 7.5 HP	162E 10 HP	162F 10 HP	162G 15 HP	172H 15 HP	172J 15 HP	172K 20 HP	172K 20 HP	173K 20 HP	173K 20 HP	174K 20 HP	
350	*	161D 7.5 HP	162D 7.5 HP	162E 10 HP	162G 15 HP	172H 15 HP	172J 20 HP	172K 20 HP	173J 20 HP	173K 25 HP	174K 25 HP			
400	*	151L 10 HP	162D 10 HP	162E 15 HP	162G 15 HP	172H 20 HP	172J 20 HP	172K 20 HP	173J 20 HP	173K 25 HP	174K 25 HP			
450	151I 7.5 HP	152I 7.5 HP	152K 10 HP	162F 15 HP	162G 15 HP	172J 20 HP	173H 20 HP	173J 25 HP	173K 25 HP	174K 30 HP	174K 30 HP			
500	151I 7.5 HP	152I 7.5 HP	163D 10 HP	163E 15 HP	163G 20 HP	164G 20 HP	173J 25 HP	174J 25 HP	174K 30 HP	174K 30 HP				
550	161D 10 HP	162D 10 HP	162E 15 HP	163E 15 HP	163G 20 HP	164G 20 HP	173J 25 HP	173K 30 HP	174K 30 HP					
600	161D 10 HP	162D 10 HP	152L 15 HP	162G 20 HP	163G 20 HP	164G 25 HP	173K 30 HP	174J 30 HP	174K 30 HP					
700	152I 10 HP	162D 15 HP	163E 20 HP	164E 20 HP	164G 25 HP	174H 30 HP	174J 30 HP	174K 40 HP						
800	152I 10 HP	163D 15 HP	163E 20 HP	164F 25 HP	164G 30 HP	174J 40 HP								
900	152I 15 HP	163D 15 HP	164E 25 HP	164G 30 HP	174J 40 HP									
1000	152I 15 HP	163D 20 HP	164E 25 HP	164G 40 HP										
1100	153I 20 HP	164D 20 HP	154L 30 HP											

Selections based on cold water flooded suction 1.0 S.G. Open Dripproof Motor.  
 Consult individual pump curve for final selection.  
 \*Refer to 140 • 240 • 180 • 280 Series Bulletin.

## Boiler Feed Selection Guide

Boiler HP	Evap Rate GPM	Pump GPM	BOILER PRESSURE IN PSI													
			15		50		100		125		150		200		250	
			Model	HP	Model	HP	Model	HP	Model	HP	Model	HP	Model	HP	Model	HP
15	1.0	3.1	141D	.3	141D	.75	142E	1.0	142E	1.5	142F	1.5	143E	2.0	144E	3.0
20	1.4	4.1	141D	.3	141D	.75	142E	1.0	142E	1.5	142F	1.5	143E	2.0	144E	3.0
25	1.7	4.4	141D	.3	141D	.75	142E	1.0	142E	1.5	143E	1.5	143E	2.0	144E	3.0
30	2.1	5	141D	.3	141D	.75	142E	1.0	142E	1.5	143E	1.5	143E	2.0	144E	3.0
40	2.8	5.6	141D	.3	141E	.75	142F	1.5	142G	2.0	143E	1.5	144F	3.0	144I	7.5
50	3.5	7	141D	.3	141F	.75	142F	1.5	143F	2.0	143F	2.0	144I	5.0	144I	7.5
60	4.2	8.3	141E	.3	141F	.75	142G	2.0	143G	2.0	143G	5.0	144I	5.0	144I	7.5
70	4.8	9.6	141F	.5	141I	1.5	142I	3.0	143I	3.0	143I	5.0	144I	5.0	144I	7.5
80	5.5	11	141F	.5	141I	1.5	142I	3.0	143I	3.0	143I	5.0	144I	5.0	144I	7.5
100	6.9	14	141G	.5	141I	1.5	142IA	3.0	143I	3.0	143IA	5.0	144I	5.0	152I	10.0
125	8.6	17.5	141I	.75	141IA	1.5	142IA	3.0	143I	3.0	143IA	5.0	144IA	7.5	152I	10.0
150	10.7	21.0	141I	.75	141IA	1.5	151I	5.0	143IA	5.0	144IA	5.0	152I	7.5	153I	10.0
200	13.8	28.0	141IA	1.0	182K	2.0	151K	5.0	152K	7.5	162D	7.5	162D	10.0	163D	15.0
250	17.3	33.0	181M	1.5	151K	3.0	152K	5.0	152K	7.5	162D	7.5	162G	10.0	153L	15.0
300	20.7	38.0	181M	1.5	151K	3.0	152K	5.0	152K	7.5	152L	10.0	162G	15.0	153L	15.0
350	24.2	43.0	181P	1.5	151L	5.0	152L	7.5	152L	10.0	152L	10.0	162G	15.0	153L	15.0
400	27.6	48.0	181R	2.0	151L	5.0	162L	7.5	152L	10.0	162G	15.0	162G	15.0	163G	20.0
500	34.5	57.0	151L	3.0	161G	5.0	162G	10.0	162G	10.0	163G	15.0	164G	20.0	173H	25.0
600	41.5	71.0	161G	3.0	161G	5.0	172H	15.0	172H	15.0	172J	20.0	173H	20.0	173K	30.0
700	43.5	77.0	161G	3.0	171K	7.5	172K	15.0	172K	15.0	173K	20.0	174H	20.0	174J	30.0

**NOTES**

Selections are for water at 200°F (Maximum) with above 3 feet NPSHA (Net Positive Suction Head Available) over NPSHR (Net Positive Suction Head Required).  
 All pumps are selected for intermittent (on-off) operation and with ODP (Open Drip Proof) motors operating at 1750RPM.  
 This selection is for reference only. Refer to the technical data of the specific model number to ascertain the suitability of the model in your application, or call the factory.  
 140 Model pump information is available in our Bulletin 140.

# Dimensions

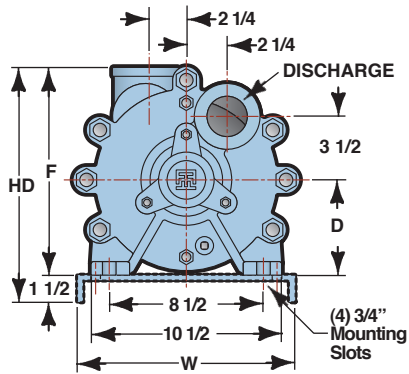
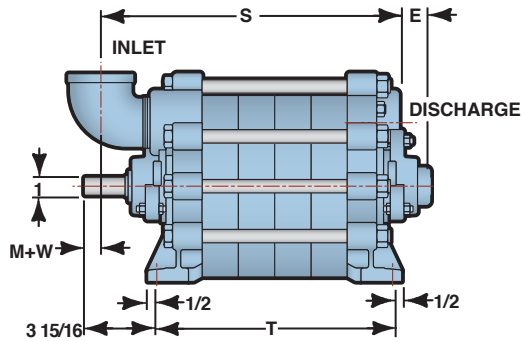

### PUMP ONLY

PUMP SERIES	INLET	DISCHARGE	E	F	M+W	S	T
151•161	2	2	2	11	1	10 1/8	7
152•162	2	2	2	11	1	12 1/8	9
153•163	2	2	2	11	1	14 1/8	11
154•164	2	2	2	11	1	16 1/8	13
171	2 1/2	2 1/2	1 13/16	11 1/2	1 1/2	12 1/2	9
172	2 1/2	2 1/2	1 13/16	11 1/2	1 1/2	16 1/2	13
173	2 1/2	2 1/2	1 13/16	11 1/2	1 1/2	20 1/2	17
174	2 1/2	2 1/2	1 13/16	11 1/2	1 1/2	24 1/2	21

ROTATION: Clockwise when viewed from driver end.

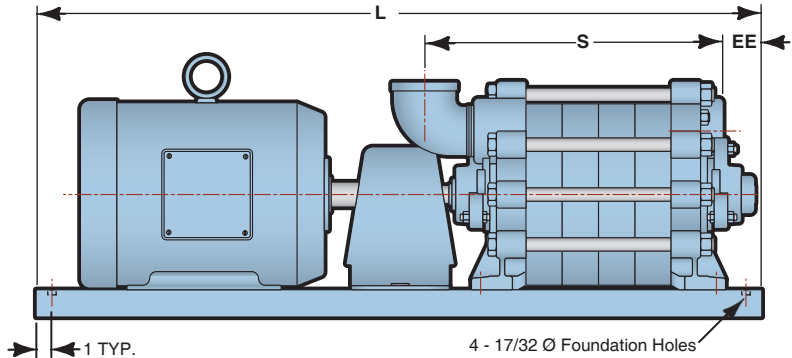

### 150 • 160 SERIES

FRAME	CPLG	ALL 150 • 160 MODELS				MODEL 151 • 161			MODEL 152 • 162			MODEL 153 • 163			MODEL 154 • 164		
		EE	D	HD	F	L	W	S	L	W	S	L	W	S	L	W	S
143T	4J	2 1/4	5 1/4	12 1/2	11	28	12	10 1/8	30	12	12 1/8	32	12	14 1/8	35	12	16 1/8
145T	4J	2 1/4	5 1/4	12 1/2	11	28	12	10 1/8	30	12	12 1/8	32	12	14 1/8	35	12	16 1/8
182T	5J	2 1/4	5 1/4	12 1/2	11	30	12	10 1/8	32	12	12 1/8	35	12	14 1/8	40	12	16 1/8
184T	5J	2 1/4	5 1/4	12 1/2	11	30	12	10 1/8	32	12	12 1/8	35	12	14 1/8	40	12	16 1/8
213T	6J	2 1/4	5 1/4	12 1/2	11	35	12	10 1/8	35	12	12 1/8	40	12	14 1/8	40	12	16 1/8
215T	6J	2 1/4	5 1/4	12 1/2	11	35	12	10 1/8	35	12	12 1/8	40	12	14 1/8	40	12	16 1/8
254T	7S	2 1/4	6 1/4	13 1/2	12	40	15	10 1/8	40	15	12 1/8	45	15	14 1/8	45	15	16 1/8
256T	8S	2 1/4	6 1/4	13 1/2	12	40	15	10 1/8	40	15	12 1/8	45	15	14 1/8	45	15	16 1/8
284T	8S	2 1/4	7	14 1/4	12 3/4	40	15	10 1/8	45	15	12 1/8	45	15	14 1/8	50	15	16 1/8
286T	8S	2 1/4	7	14 1/4	12 3/4	40	15	10 1/8	45	15	12 1/8	45	15	14 1/8	50	15	16 1/8
324T	8S	2 1/4	8	15 1/4	13 3/4	45	18	10 1/8	45	18	12 1/8	50	18	14 1/8	50	18	16 1/8
326T	8S	2 1/4	8	15 1/4	13 3/4	45	18	10 1/8	45	18	12 1/8	50	18	14 1/8	50	18	16 1/8
364T	8S	2 1/4	9	16 1/4	14 3/4	50	18	10 1/8	50	18	12 1/8	50	18	14 1/8	55	18	16 1/8

### 170 SERIES

FRAME	CPLG	ALL 170 MODELS				MODEL 171			MODEL 172			MODEL 173			MODEL 174		
		EE	D	HD	F	L	W	S	L	W	S	L	W	S	L	W	S
143T	4J	2 1/8	5 1/4	13 1/4	11	30	12	12 1/2	33	12	16 1/2	40	12	20 1/2	45	12	24 1/2
145T	4J	2 1/8	5 1/4	13 1/4	11	30	12	12 1/2	33	12	16 1/2	40	12	20 1/2	45	12	24 1/2
182T	5J	2 1/8	5 1/4	13 1/4	11	32	12	12 1/2	38	12	16 1/2	40	12	20 1/2	45	12	24 1/2
184T	5J	2 1/8	5 1/4	13 1/4	11	32	12	12 1/2	38	12	16 1/2	40	12	20 1/2	45	12	24 1/2
213T	6J	2 1/8	5 1/4	13 1/4	11	35	12	12 1/2	40	12	16 1/2	45	12	20 1/2	50	12	24 1/2
215T	6J	2 1/8	5 1/4	13 1/4	11	35	12	12 1/2	40	12	16 1/2	45	12	20 1/2	50	12	24 1/2
254T	7S	2 1/8	6 1/4	14 1/4	12	40	15	12 1/2	45	15	16 1/2	50	15	20 1/2	55	15	24 1/2
256T	8S	2 1/8	6 1/4	14 1/4	12	40	15	12 1/2	45	15	16 1/2	50	15	20 1/2	55	15	24 1/2
284T	8S	2 1/8	7	15	12 3/4	45	15	12 1/2	45	15	16 1/2	50	15	20 1/2	55	15	24 1/2
286T	8S	2 1/8	7	15	12 3/4	45	15	12 1/2	45	15	16 1/2	50	15	20 1/2	55	15	24 1/2
324T	8S	2 1/8	8	16	13 3/4	45	18	12 1/2	50	18	16 1/2	55	18	20 1/2	60	18	24 1/2
326T	8S	2 1/8	8	16	13 3/4	45	18	12 1/2	50	18	16 1/2	55	18	20 1/2	60	18	24 1/2
364T	8S	2 1/8	9	17	14 3/4	50	18	12 1/2	50	18	16 1/2	55	18	20 1/2	60	18	24 1/2

All dimensions in inches. May vary ± 1/4 inches.

# Dimensions

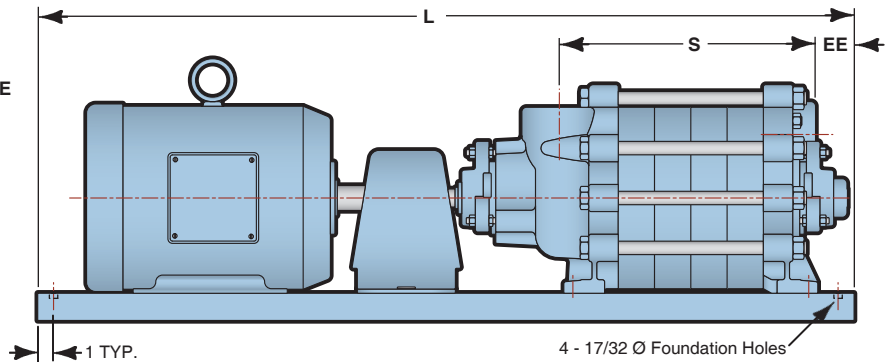
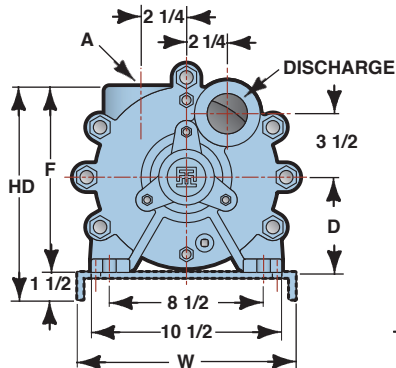
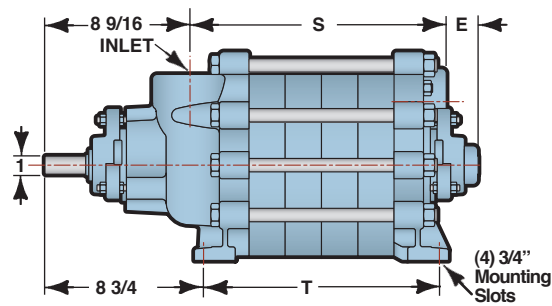

## PUMP ONLY

PUMP SERIES	INLET	DISCHARGE	E	F	S	T
251 • 261	2 1/2	2	2	10 1/4	8	7
252 • 262	2 1/2	2	2	10 1/4	10	9
253 • 263	2 1/2	2	2	10 1/4	12	11
254 • 264	2 1/2	2	2	10 1/4	14	13
271	2 1/2	2 1/2	1 3/4	10 1/4	10	9
272	2 1/2	2 1/2	1 3/4	10 1/4	17	13
273	2 1/2	2 1/2	1 3/4	10 1/4	18	17
274	2 1/2	2 1/2	1 3/4	10 1/4	22	21

ROTATION: Clockwise when viewed from driver end.

## 250 • 260 SERIES

FRAME	CPLG	ALL 250 • 260 MODELS				MODEL 251 • 261			MODEL 252 • 262			MODEL 253 • 263			MODEL 254 • 264		
		EE	D	HD	F	L	W	S	L	W	S	L	W	S	L	W	S
143T	4J	2 1/4	5 1/4	11 3/4	10 1/4	35	12	8	35	12	10	-	-	-	-	-	-
145T	4J	2 1/4	5 1/4	11 3/4	10 1/4	35	12	8	35	12	10	-	-	-	-	-	-
182T	5J	2 1/4	5 1/4	11 3/4	10 1/4	35	12	8	40	12	10	40	12	12	45	12	14
184T	5J	2 1/4	5 1/4	11 3/4	10 1/4	35	12	8	40	12	10	40	12	12	45	12	14
213T	6J	2 1/4	5 1/4	11 3/4	10 1/4	40	12	8	40	12	10	45	12	12	45	12	14
215T	6J	2 1/4	5 1/4	11 3/4	10 1/4	40	12	8	40	12	10	45	12	12	45	12	14
254T	7S	2 1/4	6 1/4	12 3/4	11 1/4	45	15	8	45	15	10	50	15	12	50	15	14
256T	8S	2 1/4	6 1/4	12 3/4	11 1/4	45	15	8	45	15	10	50	15	12	50	15	14
284T	8S	2 1/4	7	13 1/2	12	45	15	8	50	15	10	50	15	12	50	15	14
286T	8S	2 1/4	7	13 1/2	12	45	15	8	50	15	10	50	15	12	50	15	14
324T	8S	2 1/4	8	14 1/2	13	50	18	8	50	18	10	55	18	12	55	18	14
326T	8S	2 1/4	8	14 1/2	13	50	18	8	50	18	10	55	18	12	55	18	14
364T	8S	2 1/4	9	15 1/2	14	50	18	8	50	18	10	55	18	12	55	18	14

## 270 SERIES

FRAME	CPLG	ALL 270 MODELS				MODEL 271			MODEL 272			MODEL 273			MODEL 274		
		EE	D	HD	F	L	W	S	L	W	S	L	W	S	L	W	S
143T	4J	2 1/8	5 1/4	11 3/4	10 1/4	35	12	10	40	12	14	-	-	-	-	-	-
145T	4J	2 1/8	5 1/4	11 3/4	10 1/4	35	12	10	40	12	14	-	-	-	-	-	-
182T	5J	2 1/8	5 1/4	11 3/4	10 1/4	40	12	10	45	12	14	45	12	18	50	12	22
184T	5J	2 1/8	5 1/4	11 3/4	10 1/4	40	12	10	45	12	14	45	12	18	50	12	22
213T	6J	2 1/8	5 1/4	11 3/4	10 1/4	45	12	10	45	12	14	50	12	18	55	12	22
215T	6J	2 1/8	5 1/4	11 3/4	10 1/4	45	12	10	45	12	14	50	12	18	55	12	22
254T	7S	2 1/8	6 1/4	12 3/4	11 1/4	45	15	10	50	15	14	55	15	18	60	15	22
256T	8S	2 1/8	6 1/4	12 3/4	11 1/4	45	15	10	50	15	14	55	15	18	60	15	22
284T	8S	2 1/8	7	13 1/2	12	50	15	10	50	15	14	55	15	18	60	15	22
286T	8S	2 1/8	7	13 1/2	12	50	15	10	50	15	14	55	15	18	60	15	22
324T	8S	2 1/8	8	14 1/2	13	50	18	10	55	18	14	60	18	18	60	18	22
326T	8S	2 1/8	8	14 1/2	13	50	18	10	55	18	14	60	18	18	60	18	22
364T	8S	2 1/8	9	15 1/2	14	50	18	10	55	18	14	60	18	18	60	18	22

All dimensions in inches. May vary ± 1/4 inches.



*Manufacturing MTH Pumps in the  
USA since 1965*



**MTH PUMPS**

401 West Main Street • Plano, IL 60545-1436  
Phone: 630-552-4115 • Fax: 630-552-3688  
Email: [Sales@MTHPumps.com](mailto:Sales@MTHPumps.com)  
[Http://WWW.MTHPumps.com](http://WWW.MTHPumps.com)